

MT130I SR

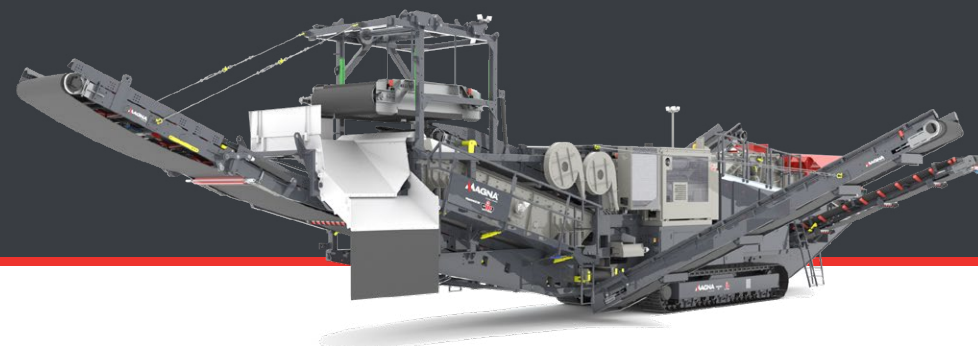

HOOPER / FEEDER

- Hopper type:** Fixed feed hopper or hydraulically foldable locking from ground level
- Hopper capacity:** 6.3m³ (8.24 yd³) / 10m³ (13 yd³)
- Hopper body:** Abrasion resistant feed hopper with optional extension available

PRE-SCREEN (OPTIONAL)

- Screen type:** Double deck
- Dimensions:** 1200mm x 2225mm (47" x 87") or 1200mm x 3160mm (47" x 125")

IMPACT CRUSHER

- Crusher inlet:** 1270mm x 925mm (50" x 36")
- Rotor diameter:** 1300mm (51")

FINAL SCREENING

- Screen type:** 2 or 3 deck options
- Screen size:** 5500mm x 2000mm (18' x 6' 6")

OUTPUT POTENTIAL

Up to 600tph / 661 US tph depending on application

POWER UNIT

Tier 3 / Tier 4F / STAGE V: CAT C15 / SCANIA DC16
(up to 450kW / 600hp)

CONVEYORS

- Product conveyor width:** 1600mm (63")
- Under screen conveyor:** 1600mm (63")
- Discharge height final product conveyor:** 3.5m – 5.2m (11' 5" – 17')

TRANSPORT (Dimensions)

- Length:** 24.2m (79' 5") depending on configuration
- Width:** 3.5m (11' 6")
- Height:** 3.9m (12' 9")
- Weight operating:** 88,000 - 100,000kg (194,006 – 220,462lbs)
- Weight transport:** 72,000 - 80,000kg (136,686 – 176,369lbs)